



SENFENG

Jinan Senfeng Laser Technology Co., Ltd.

📍 No. 1777 Kejia Road, High-tech Zone, Jinan City, Shandong Province, PRC

☎ +86 531 88737920 📞 +86 132 1054 6543 ✉ senfeng@sfcnclaser.com

🌐 www.senfenglaser.com

▶ **Germany Subsidiary**

Add: Oberer Westring 33, 33142 Büren, Germany

▶ **USA Subsidiary**

▶ **USA Subsidiary**

Add: 5989 Rickenbacker Road, Commerce CA90040

▶ **UAE Subsidiary**

Add: Al Sajaa Industrial-Al Jla'il-Sharjah-UAE

▶ **Pakistan Service Center**

Add: Dullukhur metro station 26 Ferozpur road, Lahore

▶ **India Service Center**

Add: Plot no 4/09, survey no-519, TSIIIC, ip nadergul, hyderabad

▶ **Vietnam Service Center**

Add: K13 Ngã 3 NgọcHồi Xã Ngũ Hiệp Huyện Thanh Trì Hà Nội

▶ **Jordan Service Center**

Add: Amman-Sahab-Alazraq highway

Note: The pictures and parameters in the album are for reference only, and the actual product shall prevail. Printed in May 2024

HOW TO SELECT YOUR AUTOMATION MACHINES

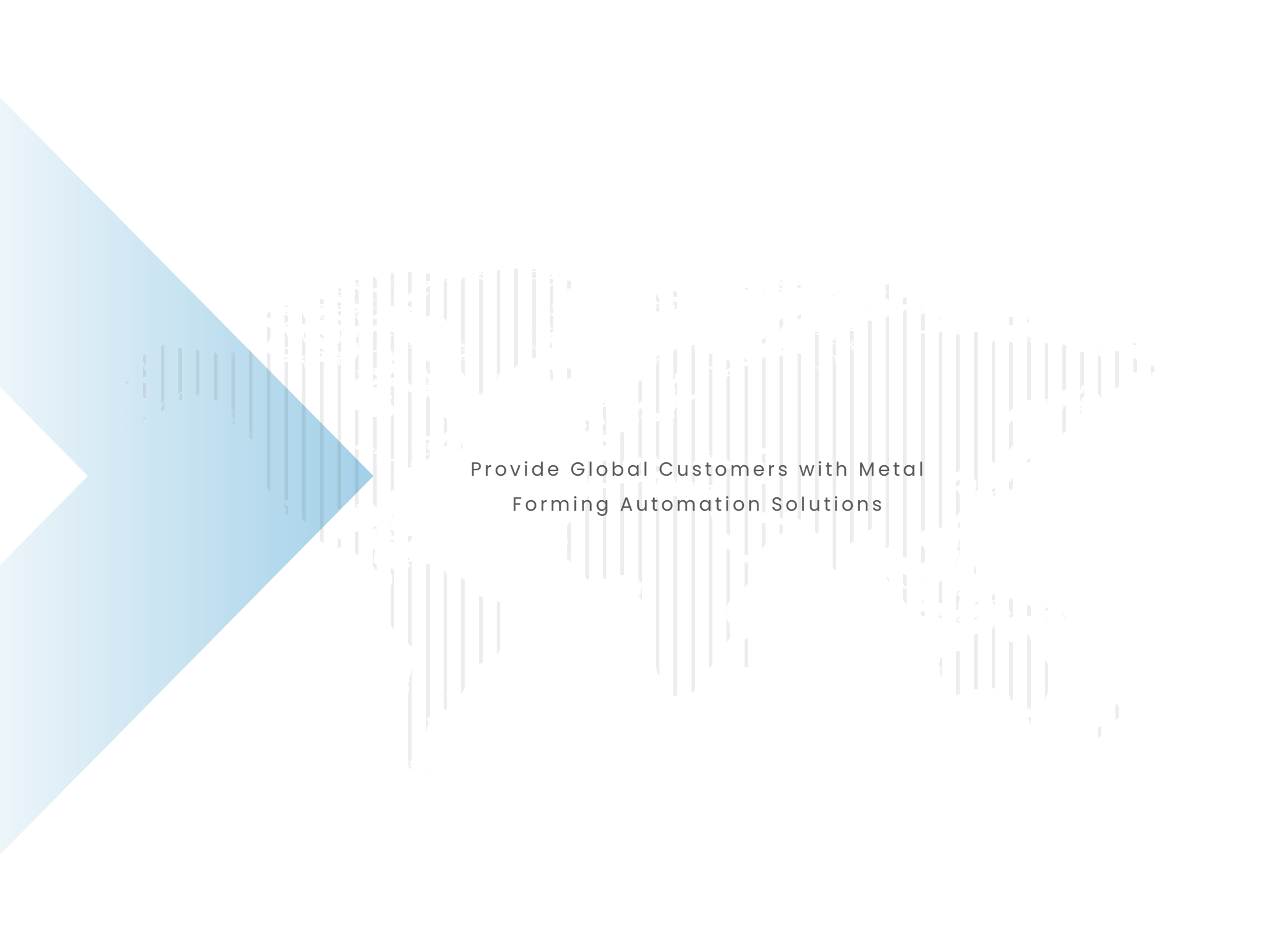

Provide Global Customers with Metal
Forming Automation Solutions

CONTENTS



1

About Automation

Automation Production Lines and Business Division

3

Applicable Industries

Practical Usage in Various Industries

2

Automation Machines

Specific Models, Competitive Strengths,
Technical Parameters and Specific Configurations

4

After-sales Service

Quick-response Service and
Globe-spanning Service Outlets

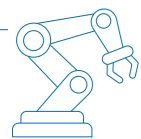
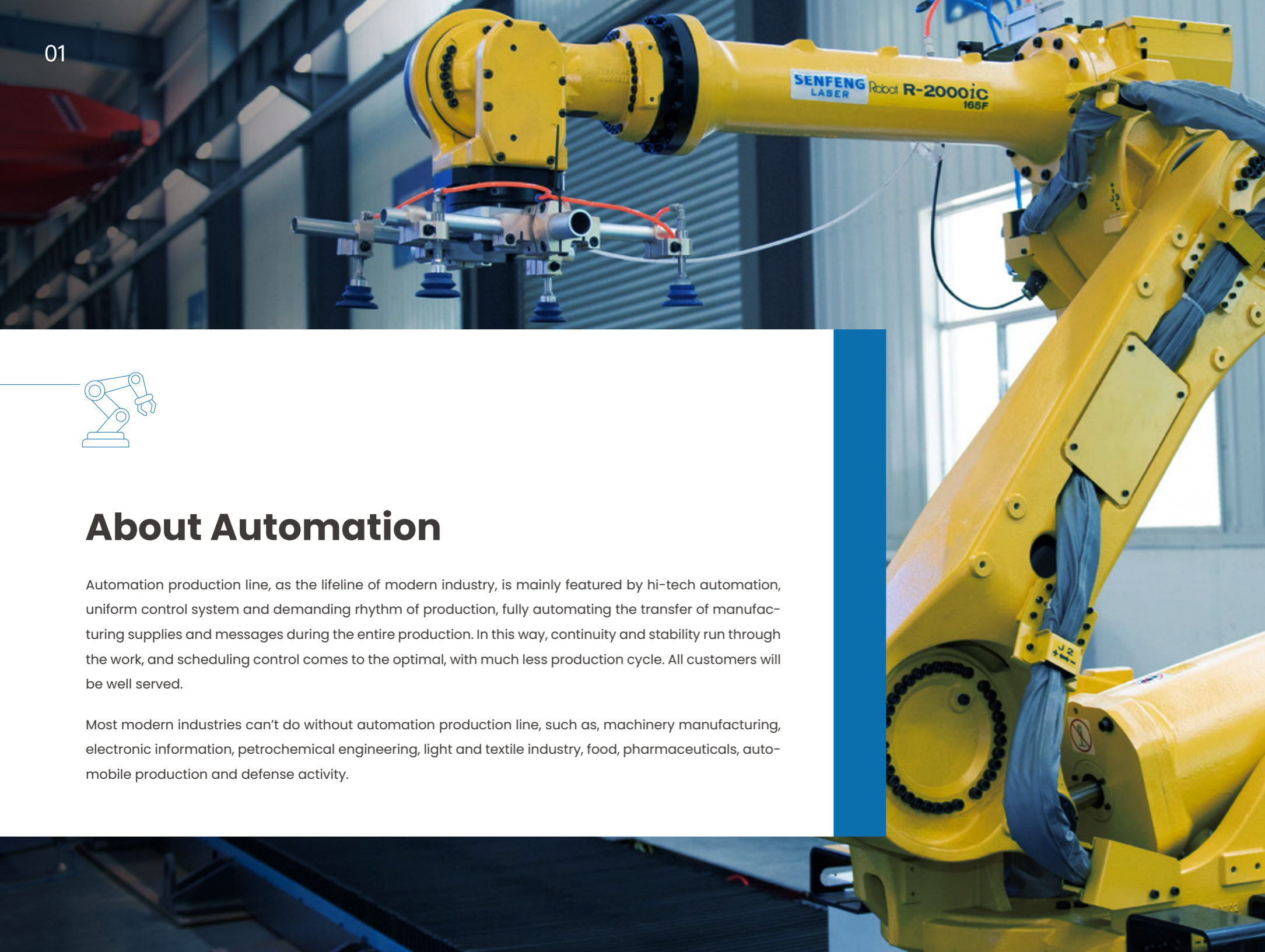

About Automation

Automation production line, as the lifeline of modern industry, is mainly featured by hi-tech automation, uniform control system and demanding rhythm of production, fully automating the transfer of manufacturing supplies and messages during the entire production. In this way, continuity and stability run through the work, and scheduling control comes to the optimal, with much less production cycle. All customers will be well served.

Most modern industries can't do without automation production line, such as, machinery manufacturing, electronic information, petrochemical engineering, light and textile industry, food, pharmaceuticals, automobile production and defense activity.

Technical Patents at Home and Abroad

With professional R&D centers and sophisticated R&D teams, we have got 577 technical patents and showcased our technical strengths to all global customers.

577 Technical Patents
By the end of Dec. 31, 2022.



International Certifications



Our export machines have got TUV-CE (EU), FDA (the United States), ETL (the North America), CSA (Canada) and many other certifications. This means that our machines have reached the world advanced level in both quality and safety.





FENGYUN Cloud System Digital and Intelligent

The system can access into other global-oriented web platforms to link up up machines, production line, staff, factory, warehouse, supplier, finished products and customers, just for sharing data and resources. In this way, the entire manufacturing process will become more digitized, networked, automatic and intelligent.

Smart Interconnection with Each User

- 
Go out with peace of mind
 Finished product positioning, track query, remote failure diagnosis, history machine failure query.
- 
Keep your machine safe
 Remote diagnosis and maintenance, redundancy, real-time record of historical data, and efficient connection with MES system in customer factory.

- 
Make high-quality plans
 Save manufacturing costs by making good-value plans after calculating the specific manufacturing and repair costs in specified algorithm.
- 
Advance into 5G era
 Use 5G technology to connect laser machines with AI, in order to make our worldwide remote diagnosis service easy and responsive.

Business Division

As global market needs are becoming more personalized, diversified and ever-changing, and labor force available is fewer and fewer, it is inevitable for mechanical machines to be automatic and intelligent. Aiming at the construction of unmanned factory, SENFENG can customize metal forming automation solutions as needed, including laser blanking lines, fully-automatic laser blanking lines, automatic loading & unloading and cutting devices, flexible laser processing lines (TOP flexible metal processing line) and other order-made machines. Laser cutting works with automation technology to make production faster, machines better and manufacturing costs lower, giving an impetus to the traditional manufacturing industry.



🔄 Laser blanking line

🔄 Flexible laser processing line

🔄 Fully-automatic laser blanking line

🔄 Order-made automatic production line

🔄 Automatic loading & unloading device

🔄 TOP flexible metal processing line

Laser Blanking Lines SF0801L

▶ Bran-new technology and outperform in work efficiency



4 Competitive Strengths

- 📦 Address traditional problems
- 🔄 Damage-free feeding
- 📏 Feeding error correction to keep cutting precision high
- 📦 Cut sheet coils at high quality and utilization rate

Technical Parameters

Model	SF0801L
Laser power	1500W
Thickness of sheet coil	0.6-1.2mm
Max weight of sheet coil	≤8T
Width of sheet coil	800mm



* Machine appearance, function description and technical parameters on this page are derived from SENFENG's Technical R&D Center based on our self-developed machines. For reference only, in kind prevail!

Laser Blanking Lines SF15015C

► New structure with high value for money



3 Competitive Strengths

-  Creative structure of integration
-  Easy to operate and intelligent control
-  Electric components at high quality

Technical Parameters

Model	SF15015C
Laser power	1500-3000W
Thickness of sheet coil	0.5-1.2mm
Max weight of sheet coil	≤10T
Width of sheet coil	600-1500mm
Loading device	Multi-split decoiler (optional)
Other functions	Sticker/ink jetting/galvanometer marking (optional)





* Machine appearance, function description and technical parameters on this page are derived from SENFENG's Technical R&D Center based on our self-developed machines. For reference only, in kind prevail!

Laser Blanking Lines SF1502C

► Easy to start your production and long service life



4 Competitive Strengths

-  Address traditional problems
-  Patented technology of high-precision error correction
-  Rapid stress relief
-  Precise, intelligent, efficient and save raw materials

Technical Parameters

Model	SF1502C
Laser power	1500-6000W
Thickness of sheet coil	0.6-2mm
Max weight of sheet coil	≤10T
Width of sheet coil	600-1500mm
Loading device	Multi-split decoiler (optional)
Cutting device	Two/three/four cutting heads (optional)
Other functions	Filming/sticker/ink jetting/galvanometer marking (optional)





* Machine appearance, function description and technical parameters on this page are derived from SENFENG's Technical R&D Center based on our self-developed machines. For reference only, in kind prevail!

Laser Blanking Lines SF1502CH

► Only click a key to get started



4 Competitive Strengths

-  Address traditional problems
-  Patented technology of high-precision error correction
-  Rapid stress relief
-  Precise, intelligent, efficient and save raw materials

Technical Parameters

Model	SF1502CH	
Laser power	1500-6000W	
Thickness of sheet coil	0.6-2mm	
Max weight of sheet coil	≤10T	
Width of sheet coil	600-1500mm	
Working area	3000*1500mm	6000*1500mm (custom-made)
Loading device	Multi-split decoiler (optional)	
Cutting device	Two/three/four cutting heads (optional)	
Other functions	Filming/sticker/ink jetting/galvanometer marking (optional)	





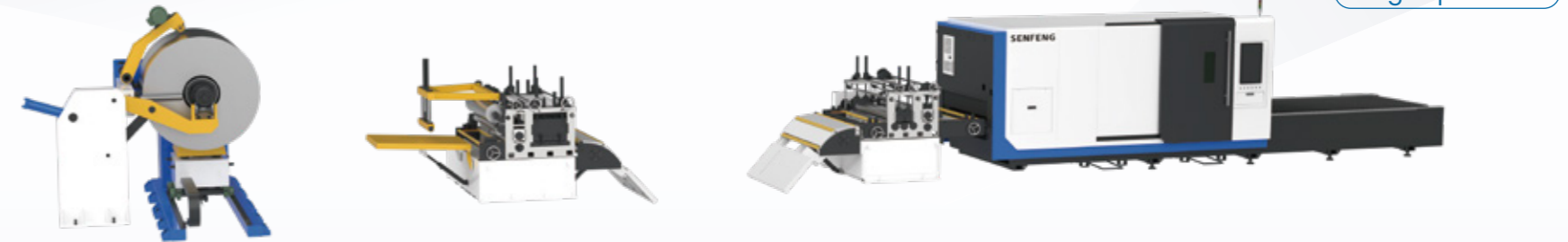

* Machine appearance, function description and technical parameters on this page are derived from SENFENG's Technical R&D Center based on our self-developed machines. For reference only, in kind prevail!

Laser Blanking Lines SF1503CH

► Load and cut sheet coils at high efficiency



6 Competitive Strengths

-  Address traditional problems
-  Patented technology of high-precision error correction
-  Automatic feeding system at high precision
-  Rapid stress relief
-  Precise, intelligent, efficient and save raw materials
-  Flexible production in batch

Technical Parameters

Model	SF1503CH	
Laser power	3000-6000W	
Thickness of sheet coil	0.8-3mm	
Max weight of sheet coil	≤15T	
Width of sheet coil	800-1500mm	
Loading device	Multi-split decoiler (optional)	
Cutting device	Two/three/four cutting heads (optional)	
Other functions	Filming/sticker/ink jetting/galvanometer marking (optional)	

* Machine appearance, function description and technical parameters on this page are derived from SENFENG's Technical R&D Center based on our self-developed machines. For reference only, in kind prevail!

Laser Blanking Lines SF1503CH

► Load and cut sheet coils at high efficiency



6 Competitive Strengths

- Address traditional problems
- Patented technology of high-precision error correction
- Automatic feeding system at high precision
- Rapid stress relief
- Precise, intelligent, efficient and save raw materials
- Flexible production in batch

Technical Parameters

Model	SF1503CH
Laser power	3000-6000W
Thickness of sheet coil	0.8-3mm
Max weight of sheet coil	≤15T
Width of sheet coil	800-1500mm
Loading device	Multi-split decoiler (optional)
Cutting device	Two/three/four cutting heads (optional)
Other functions	Filming/sticker/ink jetting/galvanometer marking (optional)

* Machine appearance, function description and technical parameters on this page are derived from SENFENG's Technical R&D Center based on our self-developed machines. For reference only, in kind prevail!

Laser Blanking Lines SF1503CLH

► Cut without limit

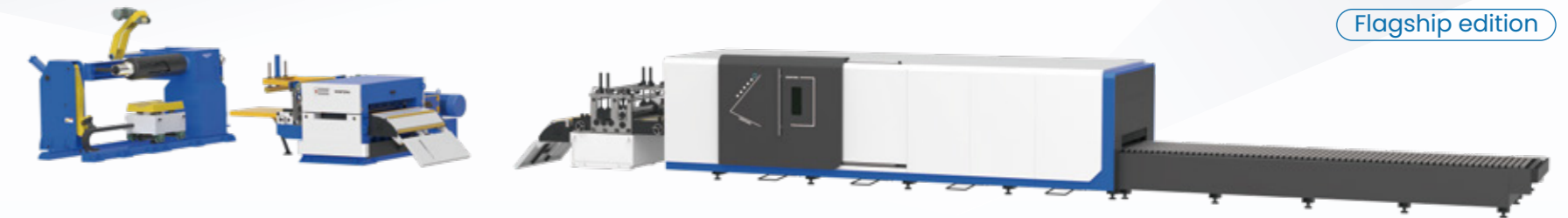

6 Competitive Strengths

- Special for non-ferrous metals
- Well designed and run stably
- Lightning-fast cutting with mirror-like surface
- Rapid stress relief
- Get CE/FDA certifications
- Flexible production in batch

Technical Parameters

Model	SF1503CLH
Laser power	3000-6000W
Thickness of sheet coil	0.8-3mm
Max weight of sheet coil	≤15T
Width of sheet coil	800-1500mm
Loading device	Multi-split decoiler (optional)
Cutting device	Two/three/four cutting heads (optional)
Other functions	Filming/sticker/ink jetting/galvanometer marking (optional)

* Machine appearance, function description and technical parameters on this page are derived from SENFENG's Technical R&D Center based on our self-developed machines. For reference only, in kind prevail!

Laser Blanking Lines SF1503CLH

► Cut without limit



6 Competitive Strengths

- Special for non-ferrous metals
- Well designed and run stably
- Lightning-fast cutting with mirror-like surface
- Rapid stress relief
- Get CE/FDA certifications
- Flexible production in batch

Technical Parameters

Model	SF1503CLH
Laser power	3000-6000W
Thickness of sheet coil	0.8-3mm
Max weight of sheet coil	≤15T
Width of sheet coil	800-1500mm
Loading device	Multi-split decoiler (optional)
Cutting device	Two/three/four cutting heads (optional)
Other functions	Filming/sticker/ink jetting/galvanometer marking (optional)

* Machine appearance, function description and technical parameters on this page are derived from SENFENG's Technical R&D Center based on our self-developed machines. For reference only, in kind prevail!

Laser Blanking Lines SF1803CLH

► Flexible production for higher quality and efficiency

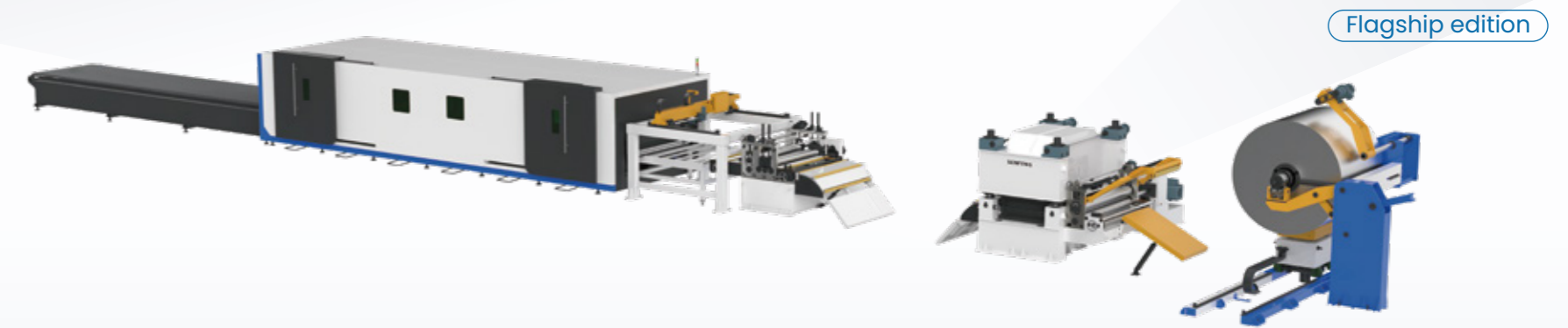

6 Competitive Strengths

- Address traditional problems
- Patented technology of high-precision error correction
- Automatic feeding system at high precision
- Rapid stress relief
- Precise, intelligent, efficient and save raw materials
- Flexible production in batch

Technical Parameters

Model	SF1803CLH
Laser power	3000-6000W
Thickness of sheet coil	0.8-3mm
Max weight of sheet coil	≤15T
Width of sheet coil	800-1800mm
Loading device	Multi-split decoiler (optional)
Cutting device	Two/three/four cutting heads (optional)
Other functions	Filming/sticker/ink jetting/galvanometer marking (optional)







* Machine appearance, function description and technical parameters on this page are derived from SENFENG's Technical R&D Center based on our self-developed machines. For reference only, in kind prevail!

Laser Blanking Lines SF1803CLH

► Flexible production for higher quality and efficiency



6 Competitive Strengths

-  Address traditional problems
-  Patented technology of high-precision error correction
-  Automatic feeding system at high precision
-  Rapid stress relief
-  Precise, intelligent, efficient and save raw materials
-  Flexible production in batch

Technical Parameters

Model	SF1803CLH
Laser power	3000-6000W
Thickness of sheet coil	0.8-3mm
Max weight of sheet coil	≤15T
Width of sheet coil	800-1800mm
Loading device	Multi-split decoiler (optional)
Cutting device	Two/three/four cutting heads (optional)
Other functions	Filming/sticker/ink jetting/galvanometer marking (optional)







* Machine appearance, function description and technical parameters on this page are derived from SENFENG's Technical R&D Center based on our self-developed machines. For reference only, in kind prevail!

Laser Blanking Lines SF2003CH

► Load and cut sheet coils at high efficiency



6 Competitive Strengths

-  Address traditional problems
-  Patented technology of high-precision error correction
-  Automatic feeding system at high precision
-  Rapid stress relief
-  Precise, intelligent, efficient and save raw materials
-  Flexible production in batch

Technical Parameters

Model	SF2003CH
Laser power	3000-6000W
Thickness of sheet coil	0.8-3mm
Max weight of sheet coil	≤15T
Width of sheet coil	800-2000mm
Loading device	Multi-split decoiler (optional)
Cutting device	Two/three/four cutting heads (optional)
Other functions	Filming/sticker/ink jetting/galvanometer marking (optional)

* Machine appearance, function description and technical parameters on this page are derived from SENFENG's Technical R&D Center based on our self-developed machines. For reference only, in kind prevail!

Laser Blanking Lines SF2003CLH

► Both flexible and high in quality and efficiency



6 Competitive Strengths

- Address traditional problems
- Patented technology of high-precision error correction
- Automatic feeding system at high precision
- Rapid stress relief
- Precise, intelligent, efficient and save raw materials
- Flexible production in batch

Technical Parameters

Model	SF2003CLH
Laser power	3000-6000W
Thickness of sheet coil	0.6-3mm
Max weight of sheet coil	≤15T
Width of sheet coil	800-2000mm
Loading device	Multi-split decoiler (optional)
Cutting device	Two/three/four cutting heads (optional)
Other functions	Filming/sticker/ink jetting/galvanometer marking (optional)

* Machine appearance, function description and technical parameters on this page are derived from SENFENG's Technical R&D Center based on our self-developed machines. For reference only, in kind prevail!

Laser Blanking Lines SF2016CH

► Reshape sheet coils by high laser energy

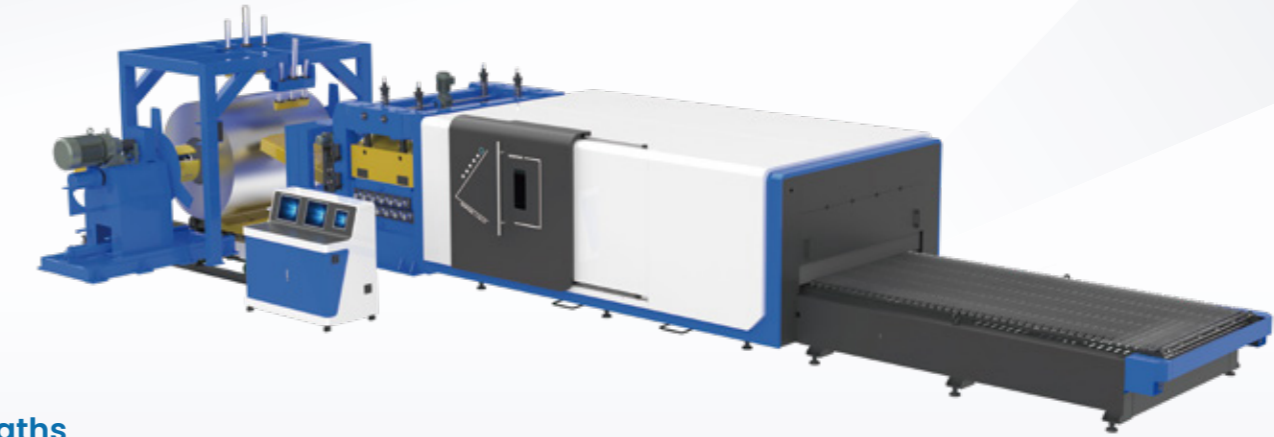

6 Competitive Strengths

- Address traditional problems
- Advanced technology and well-designed structure
- Cut sheet coils with mirror-like surface at medium-high power
- Heavy-duty structure for stable running
- Wide range of applications and easy to repair
- Flexible production in batch

Technical Parameters

Model	SF2016CH
Laser power	6000-8000W
Thickness of sheet coil	4-16mm
Max weight of sheet coil	≤30T
Width of sheet coil	800-2000mm
Loading device	Multi-split decoiler (optional)
Cutting device	Two/three/four cutting heads (optional)
Other functions	Filming/sticker/ink jetting/galvanometer marking (optional)

* Machine appearance, function description and technical parameters on this page are derived from SENFENG's Technical R&D Center based on our self-developed machines. For reference only, in kind prevail!







Follow-up Laser Blanking Line SF1603P

► High level of integration to enable automobile industry

Special solutions used for outside plates and interior trim panels of automobile



6 Competitive Strengths

-  Automatic nesting for higher utilization rate of raw materials
-  Cut into different shapes rapidly
-  Multiple cutting heads available for efficiency gains
-  Belt conveyer and hanging cutting at high quality
-  Unique follow-up gap tracking device for better dust removal
-  No investment in dies, short R&D cycle of new finished products

Technical Parameters

Model	SF1603P
Laser power	3000-6000W
Thickness of sheet coil	0.8-3mm
Max weight of sheet coil	≤15T
Width of sheet coil	600-1600mm

* Machine appearance, function description and technical parameters on this page are derived from SENFENG's Technical R&D Center based on our self-developed machines. For reference only, in kind prevail!







High-precision Leveling Machine SFE-30-1000

► Level sheets at high precision

Fit for mesh sheet, thin sheet and stamping parts, and apply to automobile production, shipbuilding and aerospace



6 Competitive Strengths

-  Green and energy-saving
-  Smart production
-  Easy to operate
-  Wide range of applications
-  High-precision leveling units available
-  Swift switch among loading and unloading

Technical Parameters

Model	SFE-30-1000
Workpiece thickness	0.3-4mm
Max leveling width	1000mm
Min length of workpiece	75mm

* Machine appearance, function description and technical parameters on this page are derived from SENFENG's Technical R&D Center based on our self-developed machines. For reference only, in kind prevail!

Sheet Cutting Automation

SL3015HL-A Loading Device for Sheet Laser Cutting Machines

► Intelligent and efficient

Free your hands and save labor forces

Its servo swing arm can grab and feed sheets automatically, and take the place of traditional sheet loading and finished product picking by hands. In doing so, workers are free from high labor intensity.

Smart control system for stable and safe work

Its control system is featured by sound detection, trouble self-diagnosis, interlocking, alarm and other defensive functions. As a timesaver, the system will make your work automatic and safe.



Technical Parameters

Model	SL3015HL-A
Cutting stroke	3000*1500mm
Loading mode	Suction cups
Unloading mode	Sidelong inserting for unloading
Max size of sheet during loading & unloading	3000*1500mm
Min size of sheet during loading & unloading	800*800mm
Max grabbing weight	≤300kg
Grabbing thickness	1-10mm

* Machine appearance, function description and technical parameters on this page are derived from SENFENG's Technical R&D Center based on our self-developed machines. For reference only, in kind prevail!

Sheet Cutting Automation

SL3015HL-B Loading & Unloading Device for Sheet Laser Cutting Machines

► Compact size but run stably

Free your hands and save labor forces

Its truss mechanical arm can grab and feed sheets automatically, and take the place of traditional sheet loading and finished product picking by hands. In doing so, workers are free from high labor intensity and potential safety hazards.

Wide range of applications

The mechanical arm above is compact-sized, stable and reliable, which also goes above safety protection and work efficiency standards. The machine has been widely used for transferring various raw materials.



Technical Parameters

Model	SL3015HL-B
Cutting stroke	3000*1500mm
Loading mode	Suction cups
Unloading mode	Sidelong inserting for unloading
Max size of sheet during loading & unloading	3000*1500mm
Min size of sheet during loading & unloading	800*800mm
Max grabbing weight	≤300kg
Grabbing thickness	1-10mm

* Machine appearance, function description and technical parameters on this page are derived from SENFENG's Technical R&D Center based on our self-developed machines. For reference only, in kind prevail!

Sheet Cutting Automation

ALU3015HL-A Pallet Racks (Together with Loading & Unloading Device) for Sheet Laser Cutting Machines

► Minimally-designed and smart storage

Automatic loading & unloading of sheets

Sheet loading & unloading are under PLC control for high degree of automation. So, sheet quality, work efficiency and manufacturing costs are the best.

Smart storage

We offer 8-tier pallet racks to store various sheets at the cost of little loading & unloading time. In this way, laser cutting keeps continuous.



Technical Parameters

Model	ALU3015HL-A
Cutting stroke	3000*1500mm
Number of tiers	6-18
Max load of single tier	3000kg
Stack-up height	280mm (with wooden pallet)
Loading mode	Suction cups
Unloading mode	Both-side inserting for unloading
Max size of sheet during loading & unloading	3000*1500mm
Min size of sheet during loading & unloading	800*800mm
Max grabbing weight	≤500kg
Grabbing thickness	1-14mm

* Machine appearance, function description and technical parameters on this page are derived from SENFENG's Technical R&D Center based on our self-developed machines. For reference only, in kind prevail!

Sheet Cutting Automation

Fully-automatic Sheet Laser Cutting Production Line

► Break with tradition

The production line works with pallet racks, compound loading & unloading device (suction cups and forks), finished product stack-up trolley and other auxiliary equipment to enable automatic loading and unloading for laser cutting machines. Flexible production in batch comes true. To be specific, sheets are transferred by forks for centralized storage. Thanks to intelligent control system, sheets are also loaded and changed by no worker. Its pallet racks may dock with one or multiple laser cutting machines synchronously.

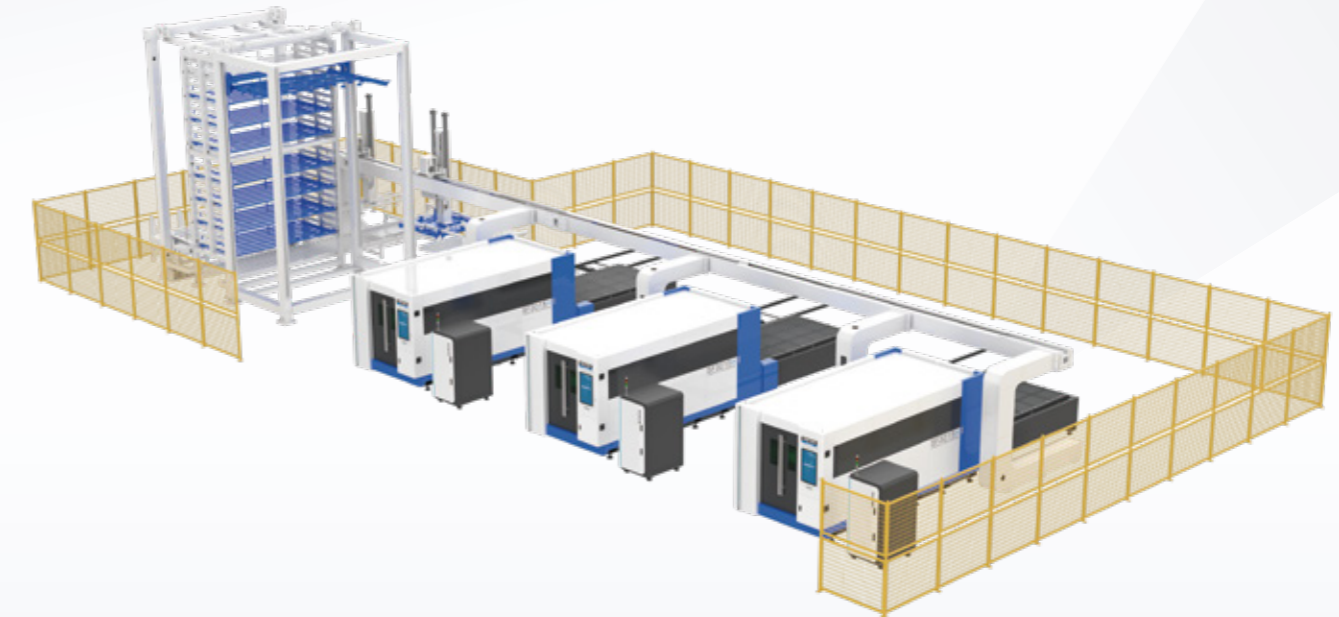

4 Constituent Parts

 Automatic loading & unloading device

 Feedstock trolley

 Laser cutting machine

 Finished products trolley

Sheet Coil Blanking Automation





ALU Fully-automatic Laser Blanking Line

► Man-machine interaction for high efficiency

It is a kind of automatic work mode that uses truss mechanical arm to grab and unload finished products automatically, which serves as a substitute of traditional manual sorting. Its unloading mechanical arm is featured by compact size, high work efficiency & transmission precision, wide range of applications, sound safety measures and efficient man-machine interaction.



4 Constituent Parts

-  Automatic unloading device
-  Feedstock trolley
-  Laser blanking line
-  Finished products trolley

Sheet Coil Blanking Automation

TOP Flexible Metal Processing Line

► Intelligent manufacturing to get ready for the future

It combines laser blanking line, flexible panel bender, automatic robot-assisted welding machine, transferring & stacking-up robots together in order to make its whole process fully automated, so that metal forming efficiency and precision are highly improved. A stand-alone machine develops into a complete production line while seeking for metal forming automation solutions. As for traditional manufacturing industry, green and sustainable development will be easy to achieve, contributing to the great progress of entire industry.



Laser blanking line

Decoil-level-cut-unload
Serialize the cutting of sheet coils

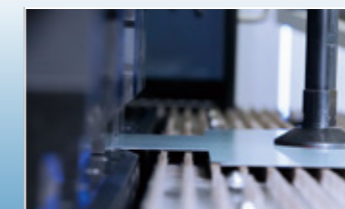

Flexible panel bender

High bending precision and consistency
among workpieces, tiny manual error



Robot-assisted laser welding machine

Flexible and efficient
to enable 360° welding at will



Transferring robot

Make its work fully automated

Automation Solutions

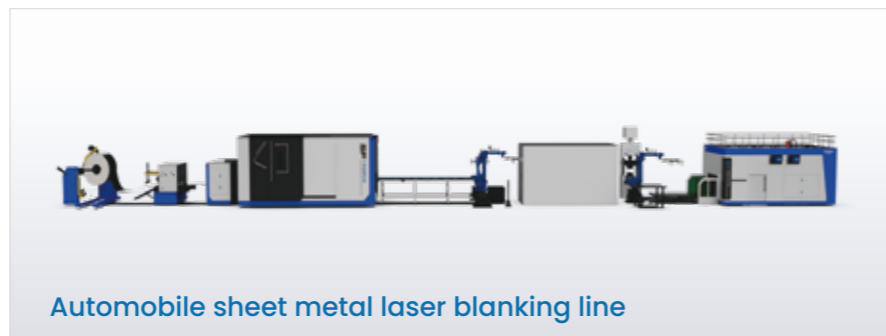

Applicable Industries

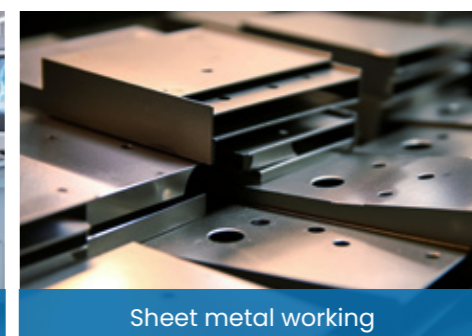
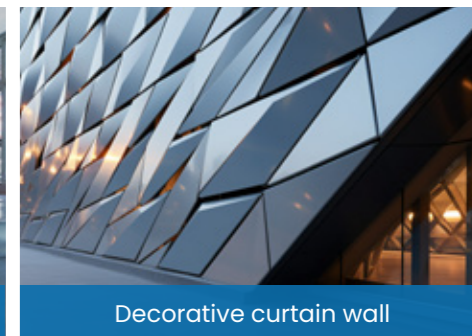
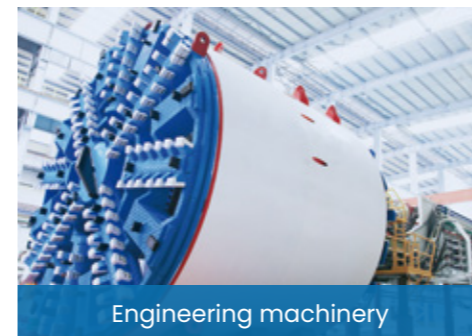

After-sales Service

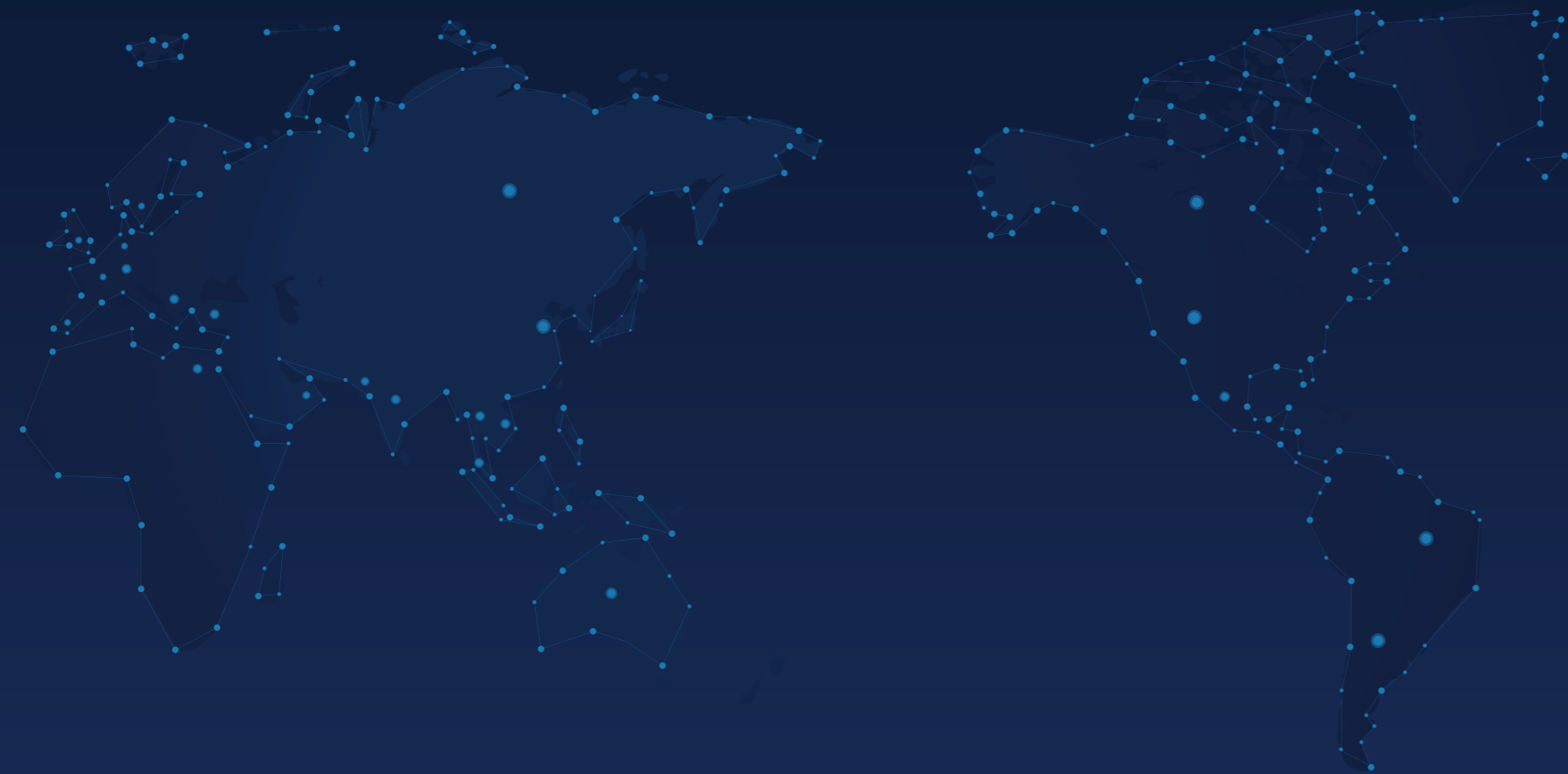

Quick-response Service



High Efficiency

Answer your repair calls for 24*7*365 days

Technical engineers can diagnose your machine within 10min, make repair plans within 1h and dispatch to your location within 1 workday after receiving your request for repair.



Craftsmanship Spirit

Provide custom-made solutions and make well-targeted plans as the case may be

Engineer certifications: Our all engineers take appointment with certificate after strict training

Train how to fix your FAQ: Collect FAQ and ask the certified engineers to train relevant customers

Online one-to-one guidance: Senior engineers guide customers to get problems solved through phone, video or other online means.

One time is enough: Commission the machine and settle similar matters only once



For Your Peace of Mind

Pre-arrival service: Train in technical theory, actual operation and troubleshooting at great length

Regular service: Reminder of maintenance, door-to-door and sales promotion service

Value-added service: Software & hardware upgrade, finance leasing and further extension of warranty period

Uphold the Spirit of Craftsmanship to
Make Our Future Smarter