

SENFENG

Cutting | Welding | Cleaning | Cladding | Bending | Milling | Automation



JINAN SENFENG LASER TECHNOLOGY CO., LTD.

📍 No. 1777 Kejia Road, High-tech Zone, Jinan City, Shandong Province, PRC

☎ +86 531 88737920 📞 +86 132 1054 6543 ✉ senfeng@sfcnclaser.com

🌐 www.senfenglaser.com 🌐 www.sfcnclaser.com

Note: The pictures and parameters in the album are for reference only, and the actual product shall prevail. Printed in Sept. 2024



About SENFENG

Provide Global Customers with Metal Forming Automation Solutions

Since the establishment of SENFENG, we have been committed to the R&D and innovation of laser technology. We're a leading manufacturer specializing in the field of laser cutting, laser welding, laser cleaning, laser cladding, industrial 3D robot, bending, milling, etc.

In order to achieve global local services more efficiently, we have established 3 subsidiaries in the USA, Germany and UAE, and 4 service centers in India, Pakistan, Vietnam and Jordan.

After years of persistent probe in the field of laser technology, we are equipped with a great pool of core tech to drive automation process of modern machinery industry.



Countries

Products all over the world

USER

America

North America: Canada, USA, Mexico
 South America: Guatemala, Honduras, Costa Rica, Panama, Jamaica, Puerto Rico, Colombia, Ecuador, Peru, Bolivia, Brazil, Chile, Argentina, Uruguay

Africa

North Africa: Egypt, Tunisia, Algeria, Morocco
 East Africa: Ethiopia, Kenya, Tanzania
 Central Africa: Republic of the Congo
 South Africa: South Africa

Oceania area

Australia, New Zealand

Europe

Nordic: Finland, Sweden, Norway, Iceland, Denmark
 Eastern Europe: Estonia, Latvia, Lithuania, Belarus, Russia,
 Central Europe: Poland, Czech Republic, Hungary, Germany, Switzerland
 Western Europe: Britain, Ireland, the Netherlands, Belgium, Luxembourg, France
 Southern Europe: Romania, Bulgaria, Serbia, Greece, Slovenia, Italy, Spain, Portugal

Asia

East Asia: China, Mongolia, Korea, Japan
 Southeast Asia: Philippines, Vietnam, Laos, Cambodia, Myanmar, Thailand, Malaysia, Brunei, Singapore, Indonesia
 South Asia: Nepal, Bangladesh, India, Pakistan, Sri Lanka
 Central Asia: Kazakhstan, Kyrgyzstan, Tajikistan, Uzbekistan, Turkmenistan
 West Asia: Iraq, Jordan, Lebanon, Israel, Saudi Arabia, Bahrain, Qatar, Kuwait, United Arab Emirates (UAE), Oman, Yemen, Georgia, Armenia, Azerbaijan, Turkey

● SENFENG USA

● SENFENG Germany

● SENFENG Jordan

● SENFENG UAE

● SENFENG Pakistan

● SENFENG India

● SENFENG Vietnam



SENFENG Laser Source

The laser source developed by SENFENG ranges from 1.5kW to 60kW, with higher electro-optical conversion efficiency and stable output power.

SENFENG Laser Head

The laser head independently developed by SENFENG has been widely used in laser cutting, welding, cleaning, cladding and other fields.

01

Auto-Focus

SENFENG users can set continuous focusing through the program to complete rapid perforation of thick plates and automatic cutting of plates of different thickness.

02

Water Cooling

The laser head focusing module is cooled by full-cycle water to reduce the fever caused by long-time cutting.

03

Lightning-fast Cutting

Lighting-fast cutting carries ultra-high power laser, combined with SENFENG cutting system technology, to achieve extreme speed cutting.

04

Shining Cutting Technology

The shining cutting technology independently developed by SENFENG Laser can effectively solve the following problems: too many burrs, the cutting surface not smooth enough and difficult to cut highly reflective materials.

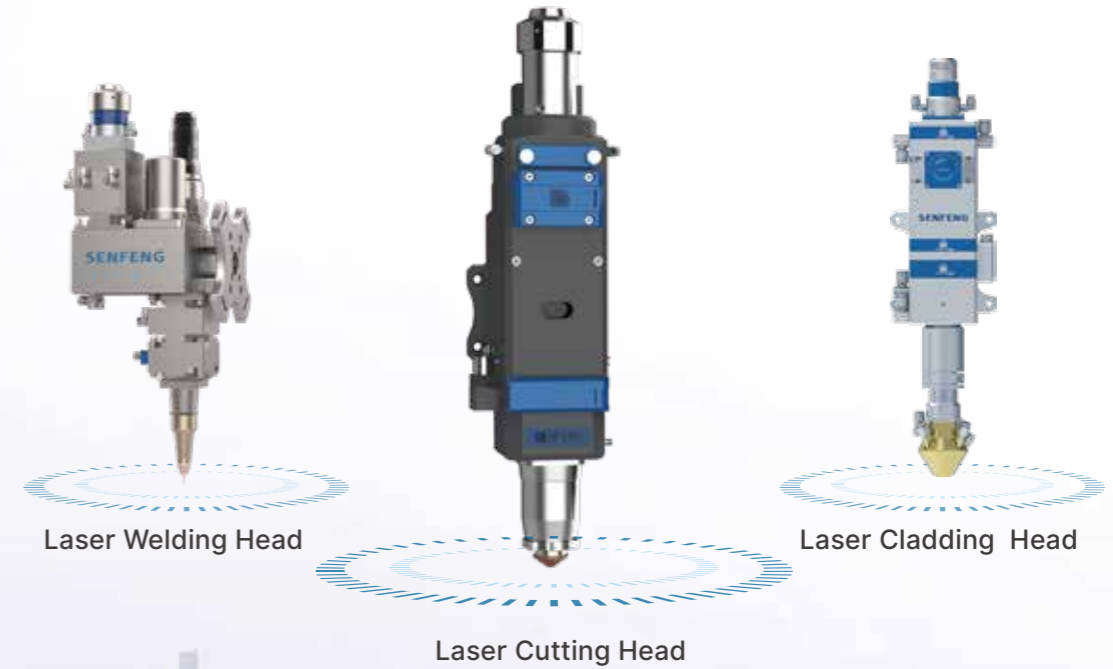

Sheet Laser Cutting Series

High-power Laser Cutting Machine

- Special for cutting thick sheet



Model	SF3015H/SF4020H/SF6015H/SF6020H/SF6025H/SF8025H/SF12025H/SF12528H
Working area	3080*1530mm/4050*2030mm/6050*1530mm/6050*2030mm/6050*2530mm/8050*2530mm/12050*2530mm/12550*2830mm
X/Y-axis positioning accuracy	±0.05mm
X/Y-axis repositioning accuracy	±0.02mm
Max speed	180m/min or 200m/min
Laser power	12-30kW

Ultra high-power Laser Cutting Machine

- Specifically for cutting thick metal



Model	SF3015H/SF4020H/SF6025H/SF8025H/SF12025H
Working area	3050*1530mm/4050*2030mm/6050*2530mm/8050*2530mm/12050*2530mm
X/Y-axis positioning accuracy	±0.05mm
X/Y-axis repeated positioning	±0.02mm
Maximum speed	2.8G
Laser power	12kW~60kW

Single Platform Laser Cutting Machine

- Cost-effective
- Easy to transport

Model	SF3015N
Working area	3050*1530mm
X/Y-axis positioning accuracy	±0.05mm
X/Y-axis repeated positioning	±0.02mm
Maximum speed	100m/min
Laser power	1.5kW~6kW

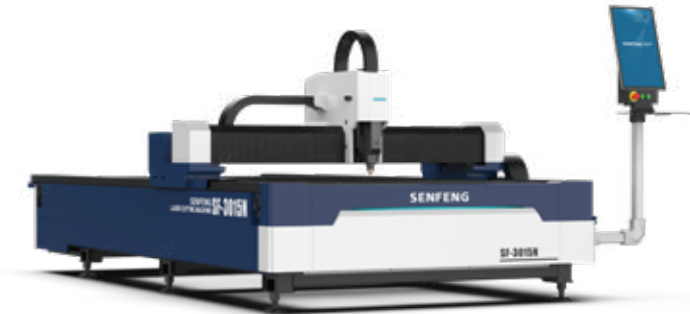

Medium-power Sheet Laser Cutting Machine

- Cut thin sheet at lightning-fast speed
- Fast to remove smoke and dust

Model	SF3015H
Working area	3050*1530mm
X/Y-axis positioning accuracy	±0.05mm
X/Y-axis repositioning accuracy	±0.02mm
Max speed	130m/min
Laser power	1.5-6kW



Small Metal Sheet Laser Cutting Machine

- Full-cover
- Manual pull-out single table

Model	SF1313G
Working area	1300*1300mm
X/Y-axis positioning accuracy	±0.05mm
X/Y-axis repeated positioning	±0.02mm
Maximum speed	80m/min
Laser power	1.5kW~3kW

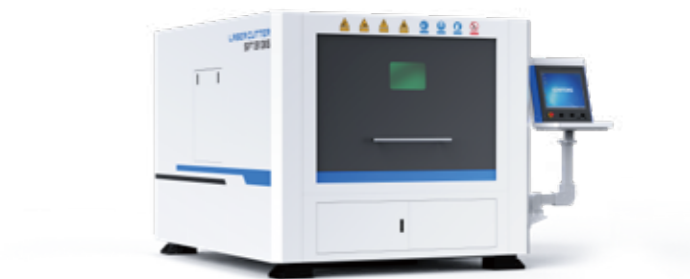

Ultra-large Series Laser Cutting Machine

- Working table length available from 12000mm to 24000mm
- Laser power available from 8kW to 60kW
- Bevel cutting available

Model	SF12030R	SF20040R	SF24040R
Working area	12000*3000mm	20000*4000mm	24000*4000mm
X/Y-axis positioning accuracy	±0.1/10000mm	±0.1/10000mm	±0.1/10000mm
X/Y-axis repeated positioning	±0.05mm	±0.05mm	±0.05mm
Maximum speed	100m/min	100m/min	100m/min
Laser power	8kW~60kW	8kW~60kW	8kW~60kW



3D Laser Cutting Series

Robot Laser Cutting Workstation



Model	SF1500RC/SF2000RC/SF3000RC
Repeated positioning accuracy	±0.02mm
Reachable radius of the robot	1853mm
X/Y-axis repeated positioning	±0.02mm
Machine power	12kW/13kW/16kW
Robot	FANUC-M-20iB
Number of control axle	6 (J1/J2/J3/J4/J5/J6)
Laser power	1.5kW~3kW

3D five-axis Cutting Machine

- 360° full surround cutting
- Fully enclosed intelligent anti-collision structure



Model	SF3015TD
Laser power	3kW
Stroke (Length*width)	3000*1500mm
Top (horizontal) machining height	0-700mm
A-axis rotation angle	±135°
C-axis rotation angle	360°*N
A/C-axis unidirectional positioning accuracy	30 Arc Sec
A/C-axis repeated positioning accuracy	7 Arc Sec

Plate & Tube Laser Cutting Series

Fully-enclosed Laser Cutter for Plate & Tube

- Cut both sheet and tube
- Efficient and cost-saving



Model	SF3015HM/SF4020HM/SF6015HM/SF6020HM
Working area	3050*1530mm/4050*2030mm/6050*1530mm/6050*2030mm
Max length of sheet	6000mm
Range of tube size	20~220mm
Max speed	130m/min
Laser power	1.5kW~6kW

Open-type Laser Cutter for Plate & Tube

- Dual function-cut metal sheet and pipe
- Efficient and cost-saving



Model	SF3015C/SF4020C/SF6015C/SF6020C
Working area	3050*1530mm/4000*2000mm/6000*1500mm/6000*2000mm
Tube diameter	20-220mm
X/Y-axis repeated positioning accuracy	±0.02mm
Laser power	1.5kW~6kW

Tube Laser Cutting Series

Two-chuck Tube Laser Cutting Machine

- Pneumatic self-centering chucks
- Follow-up or vari-pitch support available



Model	SF6016T/SF6020T/SF6024T/SF6035T
Max length of tube	6000mm
Scope of tube size	Φ10~360mm □10*10~360*360mm
Max rotating speed of chucks	60-140r/min
Max weight of tube	150-500kg

Three-chuck Zero-tailing Laser Cutting Machine

- 0 tailing because of three chucks
- Unloading device available



Model	SF6024NT/SF6035NT/SF9024NT/SF9035NT/SF12035NT
Max length of tube	6000-12000mm
Scope of tube size	Φ20~360mm □20*20~360*360mm
Max rotating speed of chucks	60-100r/min
Max weight of tube	250-1000kg

Two-chuck Bevel Laser Cutting Machine

- Cut ±45° bevel
- Handle both conventional and special-shaped tubes



Model	SF6024GT/SF6035GT
Max length of tube	6000mm
Scope of tube size	Φ10~360mm □10*10~360*360mm
Max rotating speed of chucks	60-100r/min
Max weight of tube	250-700kg

Four-chuck Heavy-duty Tube Laser Cutting Machine

- 0 tailing because of four chucks
- Come standard with loading & unloading devices
- Fit to cut large, heavy and long tube



Model	SF12050HT
Max length of tube	12000mm
Scope of tube size	Φ50~500mm □50*50~500*500mm
Max rotating speed of chucks	40r/min
Max weight of tube	2000kg

Coil-fed Laser Cutting Series

Full-cover Coil-fed Laser Cutting Machine

- 10T/15T loading capacity, triple efficiency



Model	SF1502CH
Coil thickness	0.8~2mm
Sheet width	600~1500mm
Inside and outside diameter of coil	Φ508mm/610mm≤Φ1400mm
Maximum weight of coil	10T/15T
Sheet flatness	±1.5mm/m ²
Maximum speed of sheet feeding	0~10m/min
Number of working rollers	11

Affordable Coil-fed Laser Cutting Machine



Model	SF15015C
Coil thickness	0.6~1.2mm
Sheet width	800~1500mm
Inside and outside diameter of coil	Φ508mm/610mm≤Φ1400mm
Maximum weight of coil	3T/8T/10T/15T
Sheet flatness	±2mm/m ²
Maximum speed of sheet feeding	0~10m/min
Number of working rollers	11

Aluminum Coil-fed Laser Cutting Machine

- Expert in processing aluminum coil
- Coiled material thickness:0.8-3mm



Model	SF1503CLH
Coil thickness	0.8~3mm
Sheet width	800~1500mm
Inside and outside diameter of coil	Φ508mm/610mm≤Φ1400mm
Maximum weight of coil	10T/15T
Sheet flatness	±1.5mm/m ²
Maximum speed of sheet feeding	0~10m/min
Number of working rollers	19

Heavy-load Coil-fed Laser Cutting Machine

- Max.decoil thickness 12mm
- Max coil weight: 30T

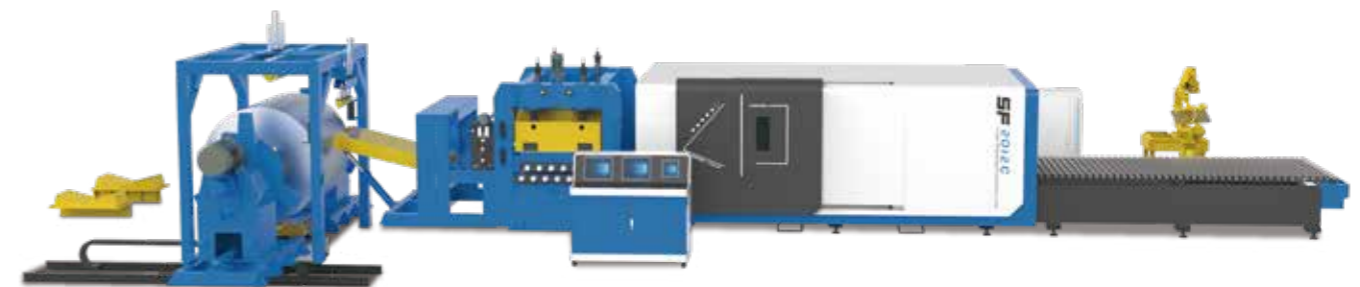

Model	SF2012CH
Coil thickness	4.0~12.0mm
Sheet width	600~2000mm
Inside and outside diameter of coil	Φ610mm/762mm≤Φ2000mm
Maximum weight of coil	30T
Sheet flatness	±2mm/m ²
Maximum speed of sheet feeding	0~10m/min
Number of working rollers	11

Laser Welding Series

Portable Handheld Laser Welding Machine

- Save space
- Easy to operate
- Cooling mode: air cooling

Model	SF3S/SF4S/SF5S
Wire feeding diameter	0.8-1.6mm
Welding thickness	Carbon steel: 0.5~5mm; Stainless steel: 0.5~5mm; Aluminum: 0.5~4mm
Working mode	Continuous
Size (W*H*D)	670mm*335mm*590mm
Cooling mode	Air cooling



Handheld Fiber Laser Welding Machine

- Save space
- Easy to operate
- Cooling mode: water cooling

Model	SF1500HWM/SF2000HWM/SF3000HWM
Laser power	1.5kW/2kW/3kW
Welding range	Carbon steel: 0.5~7mm; Stainless steel: 0.5~7mm; Aluminum: 0.5~6mm
Welding speed	≤120mm/s
Cooling mode	Water cooling



Robotic and Handheld Laser Welding Machine

- Double function: handheld welding and robotic welding

Model	SF1500HWR/SF2000HWR/SF3000HWR
Laser power	1.5kW/2kW/3kW
Robot	CRP-RH18-20
Welding range	Carbon steel: 0.5~7mm; Stainless steel: 0.5~7mm; Aluminum: 0.5~6mm
Welding speed	≤180mm/s
Welding head	Handheld, facula-adjustable welding head



3D Robot Fiber Laser Welding Machine

Model	SF1500RW/SF2000RW/SF3000RW/SF6000RW/SF12000RW/SF20000RW
Laser power	1.5kW/2kW/3kW/6kW/12kW/20kW
Robot	FANUC-M-20iD/25
Welding thickness	0.5~12mm
Welding head	Wobbler welding head



Gantry Robot Welding Machine

- Weld various special-shaped metal
- High automation, save labor cost

Model	SF1500RW/SF2000RW/SF3000RW/SF6000RW/SF12000RW/SF20000RW
Laser power	1.5kW-20kW
Robot	FANUC-M-20iD/25
Reachable radius	1853mm

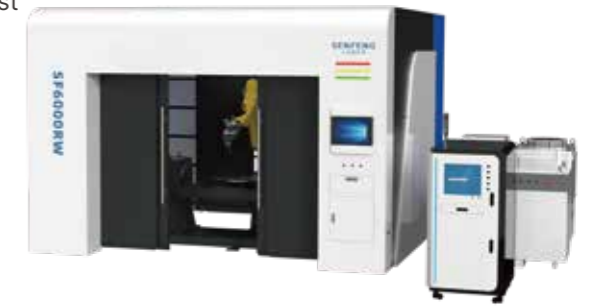

Laser Cleaning Series

Pulse Fiber Laser Cleaning Machine

- Intelligent metal surface cleaning method

Model	SF200HC/SF300HC/SF500HC/SF1000HC
Laser power	0.2kW/0.3kW/0.5kW/1kW
Cleaning width	≤200mm
Maximum single pulse energy	5MJ/15MJ/50MJ/50MJ/
Type of cooling	Air-/water-cooled



SF200HC/SF300HC (air-cooled) SF500HC/SF1000HC (water-cooled)

Continuous Fiber Laser Cleaning Machine

- Intelligent metal surface cleaning method

Model	SF1500HC/SF2000HC/SF3000HC
Laser power	1.5kW/2kW/3kW
Cleaning width	Single-swing mode≤300mm, Dual-swing mode≤800mm
Applied materials	Oil removal, rust removal, paint removal, etc.
Fiber length	≤2000W 10m, ≤3000W 15m



Robotic and Handheld Laser Cleaning Machine

- Double function: handheld cleaning and robotic cleaning

Model	SF1500HCR/SF2000HCR/SF3000HCR
Laser power	1.5kW-3kW
Applied materials	Oil removal, rust removal, paint removal, etc.
Robot load	20kg
Robot arm span	1730mm
Laser wave length	1080±10nm
Dimensions	3000*2500*2000mm



Metal Sheet Bending Machine

CNC Press Brake

- Various worktable sizes optional
- Easy to achieve thick plate bending

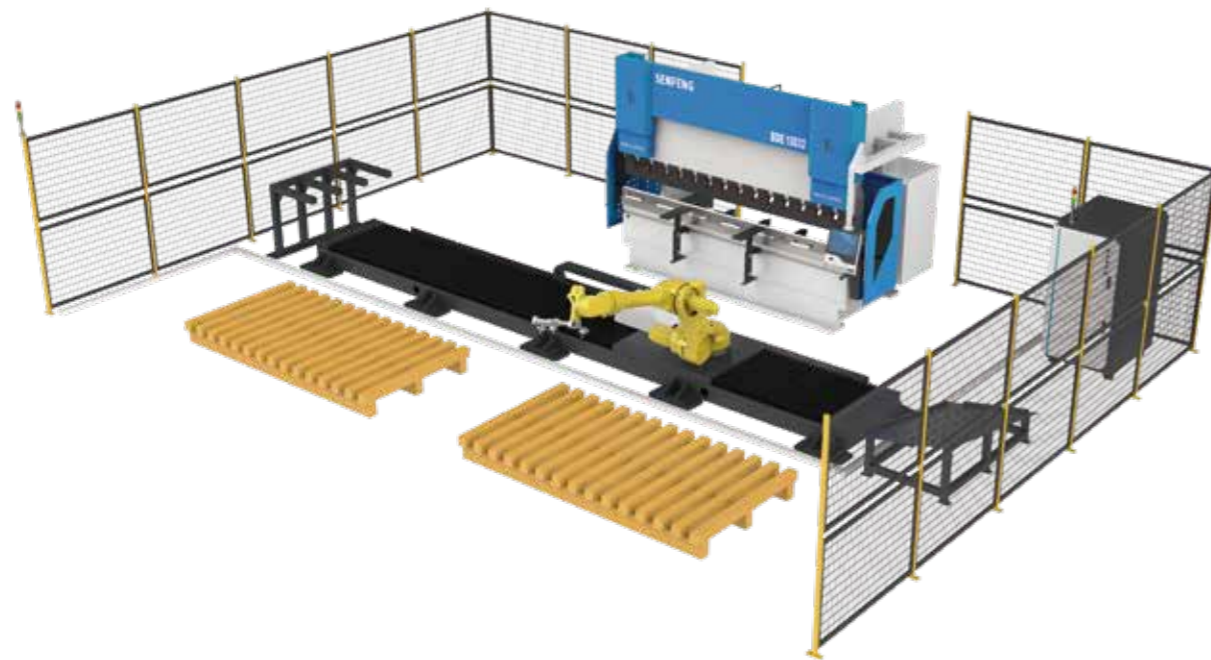

Model	BDE13032		
Metal plate materials	Stainless steel	Carbon steel	Aluminum plates
Bending thickness	2.5mm	3.5mm	5mm
Bending length	3200mm		
Open height	480mm		

Panel Bender

- Save time and improve production capacity
- High-precision thick plate bending
- Bending height can reach 200mm



Model	BDC-1500/BDC-2000/BDC-2500		
Feeding type	Downward pressing		
Maximum bending length	1500mm/2000mm/2500mm		
Maximum bending width	1250mm		
Maximum bending height	200mm (optional:300mm)		
CNC axis number	13		

Model	BDC1500	BDC2000	BDC2500
Carbon steel	2mm	2mm	2mm
Stainless steel	1.5mm	1.5mm	1.5mm
Aluminum plate	2.5mm	2.5mm	2.5mm

Note: The above parameters are the bending thickness of whole plates, not the maximum bending thickness.

Laser Cladding

Robot Laser Cladding Machine

- Support special and complex workpieces processing
- High level of process automation
- Inner hole laser cladding optional



Model	SFR6063
Laser power	6kW/12kW
Machine length	3m/6m/9m/12m/15m
Robot	KUKA KR20 R1810-2
Biaxial positioner	Swing 120-degree; Rotate 360-degree
Cladding thickness	0.1~1.5mm

Mobile Robot Laser Cladding Machine

- Smaller overall size
- More precise clad placement
- Inner hole laser cladding optional



Model	SFMR01	SFMR02
Laser power	6kW/12kW	6kW/12kW
Industrial robot model	KUKA KR20 R1810-2	KUKA KR20 R1810-2
Robot arm range	1831mm	1831mm
Cladding thickness	0.1~1.5mm	0.1~1.5mm
Cladding layer characteristics	restoration/wear-resisting/corrosion-resisting and so on	restoration/wear-resisting/corrosion-resisting and so on

Ultra-high Speed Laser Cladding Machine

- Denser coatings with little or no porosity
- Consistent layer thicknesses
- Low heat input process and low distortion
- Inner hole laser cladding optional



Model	SFHS3050/SFH3050
Laser power	6kW/12kW
Machine length	3m
Maximum rotation diameter	800mm
Rotation rate	200r/min
Cladding thickness	0.1~1.5mm

Multi-functional Inner & Outer Wall Laser Cladding Machine

- Closed structural design
- Equipped with integrated automatic lubrication system



Model	SFCS3050
Laser power	6kW/12kW
Machine length	3m
Maximum rotation diameter	1200mm
Maximum workpiece length	3000mm
Maximum load	2t

CNC Milling Machine

Vertical Machining Center Series



Item	Detail	Unit	SF-VL855	SF-VL1160	SF-VL1370	SF-VL1580	SF-VL1690
Worktable	Worktable Dimension	mm	1000×550	1200×600	1400×700	1600×800	1600×800
	Maximum Load	kg	500	800	800	1500	1500
	T-Slot Size	mm	5-18-90	5-18-100	5-18-130	7-22-110	7-22-110
Processing Range	3-Axis Travel	mm	800×550×550	1100×600×600	1300×700×700	1500×800×700	1600×900×700
	Distance From Spindle Nose To Table Surface	mm	120-670	120-720	120-870	160-860	150-850
Spindle	Distance From Spindle Center To Z-Axis Guideway Surface	mm	590	650	722	855	910
	Taper Hole (7:24)	/	BT40 φ150	BT 40 φ150	BT40 φ150	BT 50 φ 155	BT50 φ190
	Speed Range	r/min	8000	8000	8000	6000	6000
Feed	Spindle Motor Power	kW	7.5	11	15	15	11
	3-Axis Rapid Speed	m/min	32/32/24	24/24/18	24/24/18	24/24/24	20/20/12
Tool Changer	Feed Speed	mm/min	1-10000	1-10000	1-10000	1-10000	1-10000
	Type	/	Disc	Disc	Disc	Disc	Disc
	Capacity	/	24T	24T	24T	24T	24T
Positioning Accuracy	Tool Change Time	s	2.5	2.5	2.5	2.5	2.5
	X/Y/Z Axis Positioning Accuracy	mm	0.008	0.008	0.008	0.008	0.008
Other	X/Y/Z Axis Repeated Positioning Accuracy	/	0.005	0.005	0.005	0.005	0.005
	Dimension (L×W×H)	mm	2600×2380×2400	3100×2500×2800	3550×2700×2600	4300×3200×2800	4200×3262×3672
	Machine Weight Approx.	kg	5300	6500	8000	10000	12000

CNC Mill Roll Lathe



Item	Detail	Unit	Specification
Performance	Maximum steady turning diameter	mm	φ630
	Maximum turning length	mm	3000
	Distance between two tops	mm	3300
	Clamp-Top device(load bearing)	Ton	5
Spindle	Spindle speed range	r/min	4-285
	Spindle maximum torque	N·m	3700
Precision	Positioning accuracy(ISO230-2)	mm	X:0.016 Z:0.05
	Repeated positioning accuracy(ISO230-2)	mm	X:0.006 Z:0.013
Others	Machine tool area (length*width)	mm	7430*2490
	Net weight of machine tool	KG	16000
	CNC system (other systems are optional)	-	SINUMERIK-828D

Horizontal CNC Lathe



Item	Detail	Unit	SFE200
Performance	Swing Over Bed	mm	φ655
	Swing Over Carriage	mm	φ560
	Max.machining diameter	mm	φ380
Spindle	Max.turning lengt	mm	530
	Spindle speed	rpm	4000
Tool	Power	kw	15/11
	Tool Magazine Capacity	-	12
Feed	Tool Size	mm	□25 / φ40
	X-axes	mm	210
Accuracy	Z-axes	mm	530
	Position Accuracy	mm	±0.007
	Repeatability	mm	±0.003
Other	Chuck	Inch	8
	System	-	FANUC 0i-TF,10.4"

Gantry Machining Center Series



Model	Table Size	X-aix Travel	Y-aix Travel	Z-aix Travel	Gantry Span	Motor Power	Rapid Feedrate
SFF3840	3000×4000mm	4200mm	4200mm (4600mm)	1000mm (1250mm)	3800mm (4200mm)	22/26	12/12/10m/min
SFF3860	3000×6000mm	6200mm	4200mm (4600mm)	1000mm (1250mm)	3800mm (4200mm)	22/26	12/12/10m/min
SFF3880	3000×8000mm	8500mm	4200mm (4600mm)	1000mm (1250mm)	3800mm (4200mm)	22/26	10/12/10m/min
SFF38100	3000×10000mm	10500mm	4200mm (4600mm)	1000mm (1250mm)	3800mm (4200mm)	22/26	8/12/10m/min
SFF38120	3000×12000mm	12500mm	4200mm (4600mm)	1000mm (1250mm)	3800mm (4200mm)	22/26	8/12/10m/min
SFF38140	3000×14000mm	14500mm	4200mm (4600mm)	1000mm (1250mm)	3800mm (4200mm)	22/26	8/12/10m/min

A Production Line Turns Raw Material to End-products

Coil-straighten; Laser cutting; Panel bending; Laser welding; Diverse optional modules

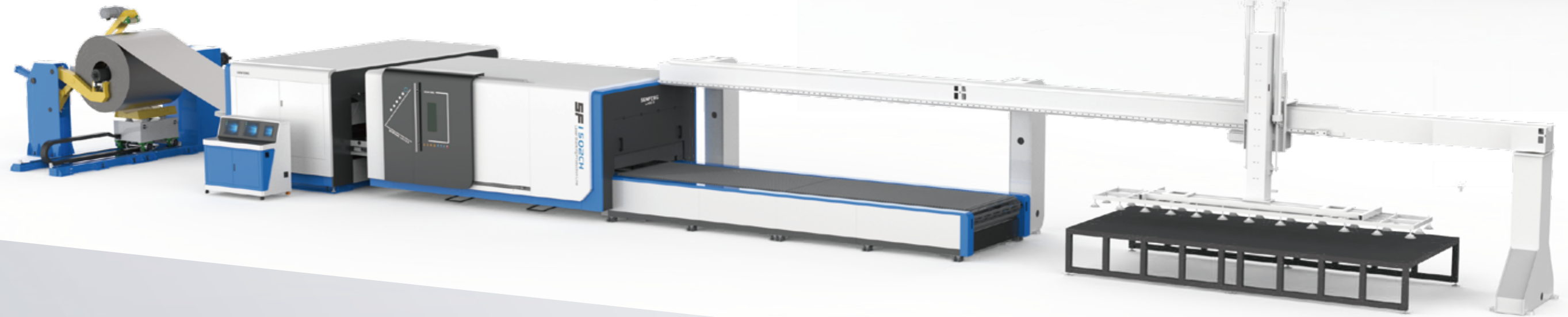
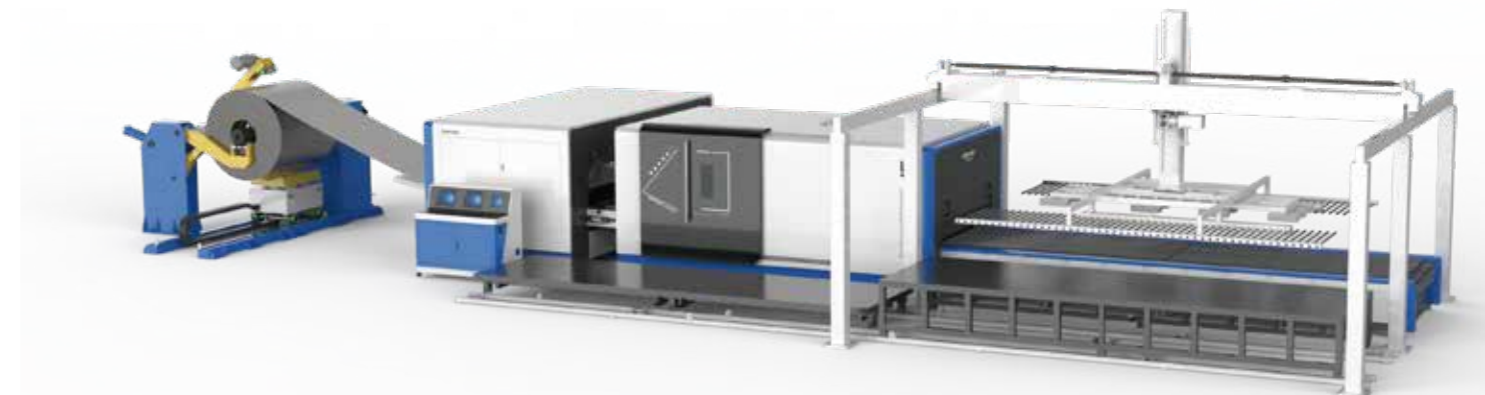

Decoil



Coil-straighten



Laser Cutting



Transfer Arm



Panel Bending



Laser Welding

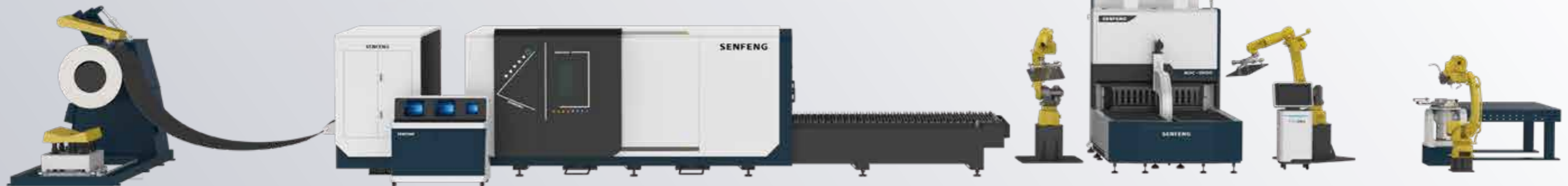



Automatic Laser Cutting Production Line

- Realizing unmanned continuous operation
- Can be customized according to specific workshop processing needs

Full-automatic Laser Loading & Unloading and Cutting Unit

The laser processing automation unit adopts the truss manipulator to automatically grab and unload materials, replacing the traditional manual plate loading and finished material picking. Laser cutting machine feeding manipulator compact and reasonable structure, stable and reliable action, can be widely used in all kinds of cutting material handling operations. Research and design of the truss type laser cutting machine loading and unloading manipulator in safety protection, work efficiency and other aspects to achieve higher requirements.



Certifications

We have passed CE from TÜV, ROHS, FDA, ETL certificates, which is in line with European and American standards.





10 Minutes Quick Response

24/7 available for your call.
Professional technical engineers reply with a solution within 10 minutes after submitting for repair.



Consultant Customization Services

Specialized program customization services: customization of service schemes based on specific conditions.
Certification system for service engineers: engineers are strictly assessed and certified.
Training on frequent questions: make a book of frequent questions and train customers by certified engineers.
On-line one-to-one guidance: senior engineers guide customers to solve problems through telephone, video and other network modes.
One time: once the equipment is debugged and the same kind of error won't reoccur.



Regular Inspection

Front-end service: detailed training of technical theory, practical operation and troubleshooting.
Regular service: regular maintenance reminder, regular service, regular promotional activities.
Value-added services: equipment software and hardware upgrading services, financial leasing services, extended warranty.